

# creva

table

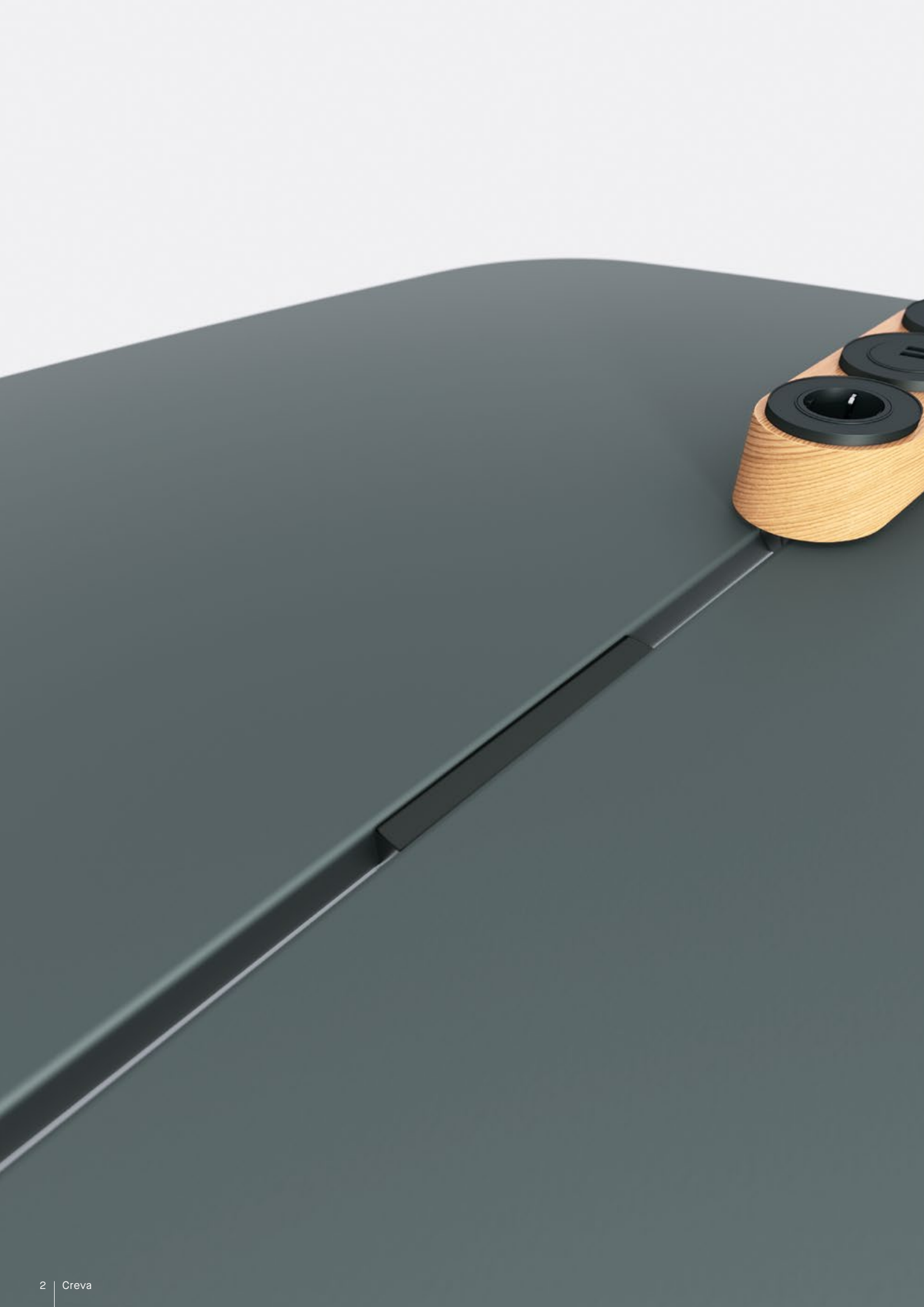

KUSCH+CO



Creva – an extraordinary table series that succeeds in transposing the design aesthetics of home furniture to the office environments. Its minimalist design language is typified by round shapes and well-balanced proportions. The materiality of the natural material wood reinforces this aura. A multitude of ingenious features is incorporated into the table construction. The rail-free substructure offers plenty of legroom. The steel leg mountings with aluminium supporting beams combined with the steel lateral bars guarantee the best possible stability. The central joint in the table top can hold a variety of freely positionable power modules, view protection panels and trays. Creva excels in versatility – ideally suited for either individual workstations or large-scale conference configurations, not forgetting the bar tables. Geared towards a plethora of environments, from offices to staff restaurants and cafeterias, from recreation rooms to waiting areas, from meeting points to break-out areas.



#### Content

Variations	10
Product data	16
Materials	31
Fire Prevention, quality, sustainability	32



#### Design by kaschkasch

In 2011, Florian Kallus and Sebastian Schneider founded their own design studio. This duo focuses their creative energy on product design & art direction. In co-operation with companies like Kusch+Co, they create classical and modular furniture designs, characterised by a synthesis of innovation, functionality and aesthetics.











KUSCHCO





# Variations

---

## Creva square / rectangular / curved rectangle table, without top joint

An exceptional wide spectrum of tables geared towards a plethora of environments. Available with a square table top measuring 150 × 150 cm. Either rectangular or curved rectangle table tops in a variety of widths up to 180 cm and lengths up to 420 cm. All table variations come with ample overhang on the sides, offering plenty of legroom.



---

## Creva round table, without top joint

The round table is available with two table top sizes, either with a 120 cm or a 150 cm diameter. Featuring a large overhang on all sides.



---

## Creva rectangular / curved rectangle bar table, without top joint

The bar table has become a favourite meeting point. Either for a spontaneous exchange of ideas while standing or a short meeting on the bar stools with matching design aesthetics. Available either with a rectangular or a curved rectangular table top measuring 100 cm resp. 110 cm in width and 200 cm in length.



---

## Creva rectangular / curved rectangle table, with top joint

A multifunctional table geared towards a plethora of environments. The central joint is designed to hold a variety of power modules, view protection panels and trays. Available with either rectangular or curved rectangle table tops in a wide variety of widths up to 180 cm and lengths up to 420 cm. All table variations come with ample overhang on the sides, offering plenty of legroom.



---

## Creva rectangular / curved rectangle bar table, with top joint

The bar table variation excels in functionality through the central joint combined with the optional extras. Ideally suited for work, either while standing or sitting on a bar stool. Available either with a rectangular or a curved rectangle table top measuring 100 cm resp. 110 cm in width and 200 cm in length.











# Product data

## Creva table, without top joint

### CREVA MEETING TABLE SQ

Square table,  
without top joint

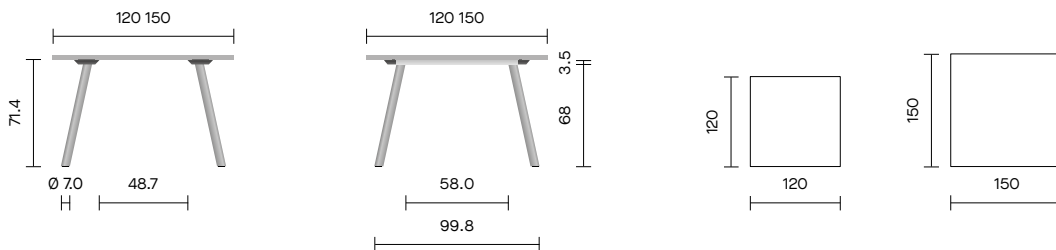

### CREVA MEETING TABLE RC

Rectangular table,  
without top joint

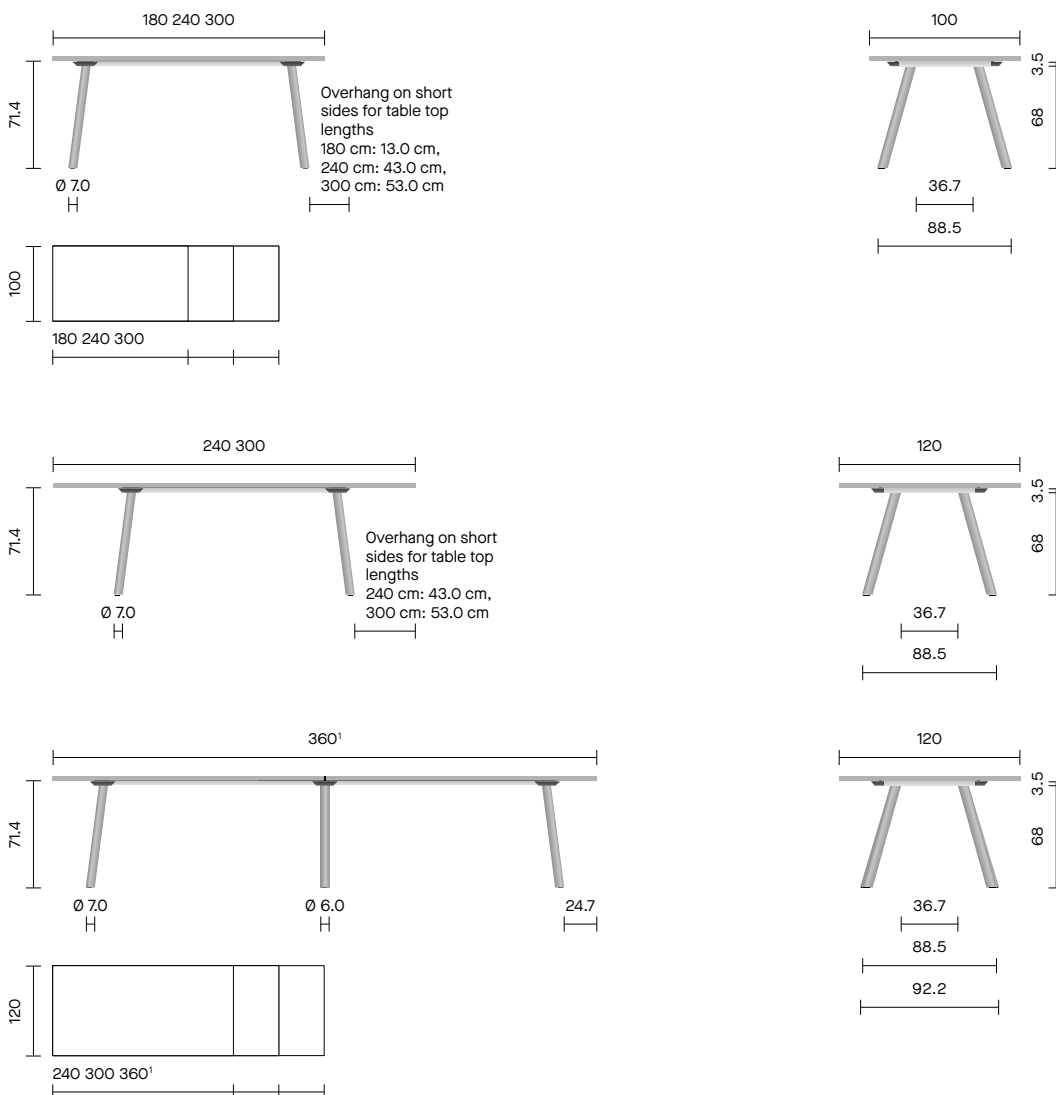

<sup>1</sup> Top in two parts  
<sup>2</sup> Top in four parts

Dimensions in cm



Creva table, without top joint

**CREVA MEETING TABLE RC**

Rectangular table,  
without top joint

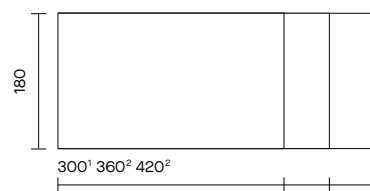
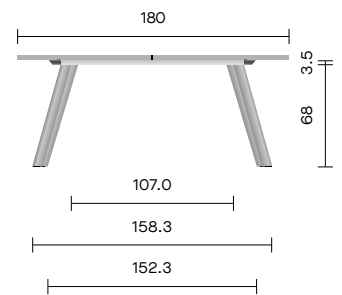
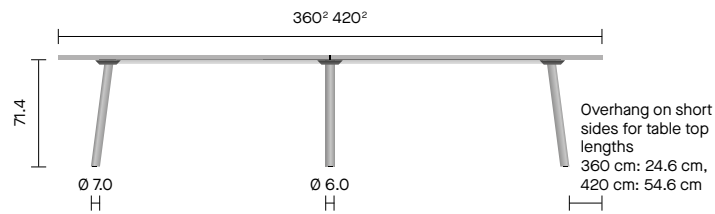
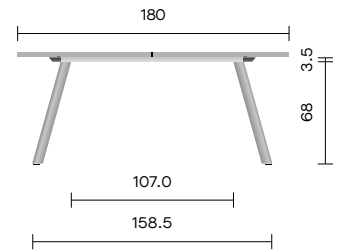
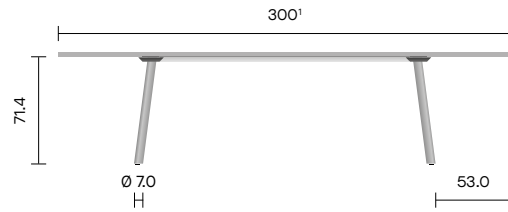
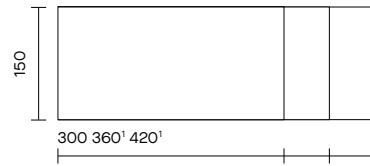
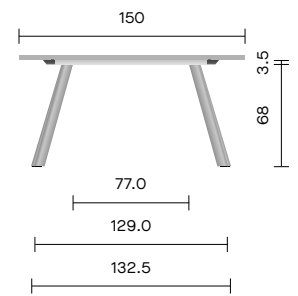
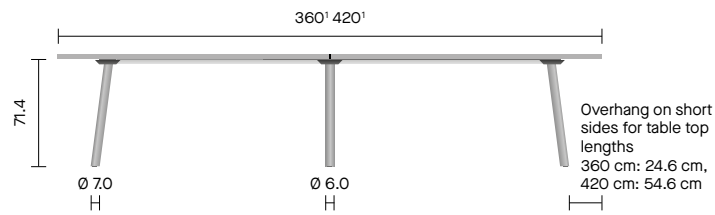
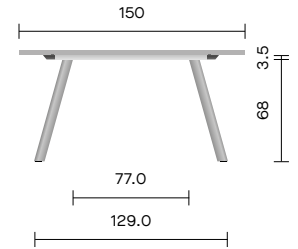
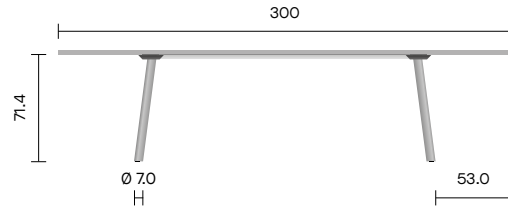

# Product data

## Creva table, without top joint

### CREVA MEETING TABLE RD

Round table,  
without top joint

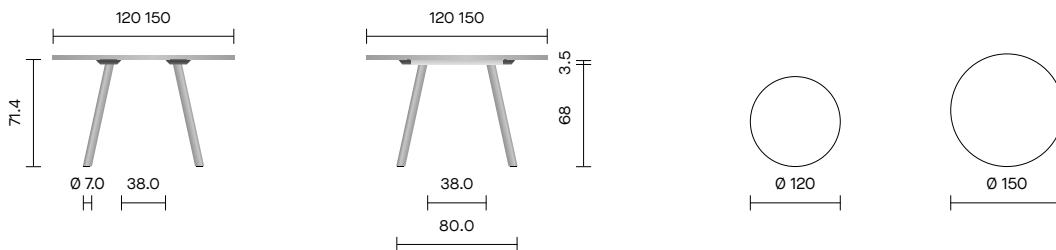

### CREVA MEETING TABLE RCR

Curved rectangle table,  
without top joint

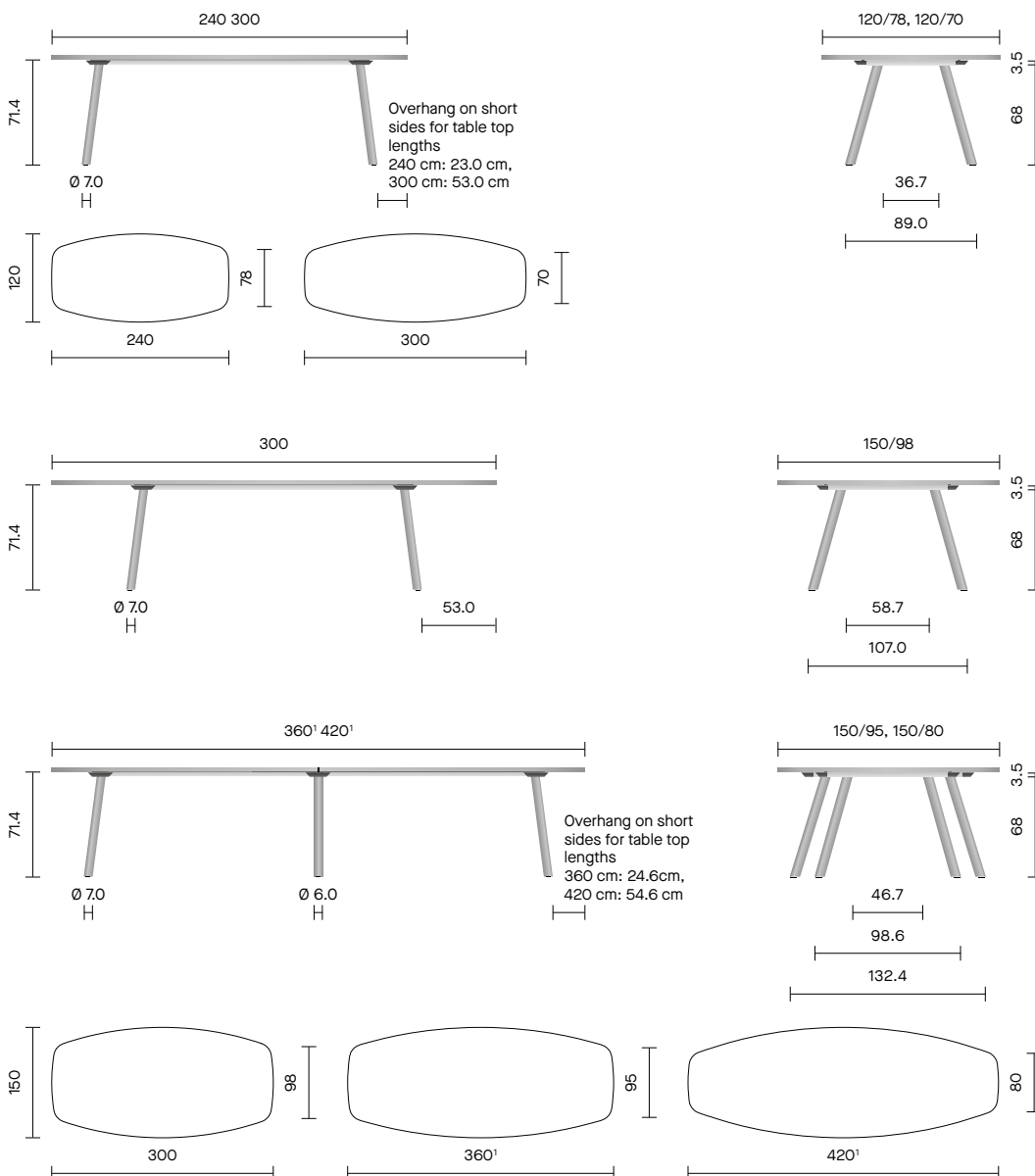

<sup>1</sup> Top in two parts  
<sup>2</sup> Top in four parts

Dimensions in cm

Creva table, without top joint

**CREVA MEETING TABLE RCR**

Curved rectangle table,  
without top joint

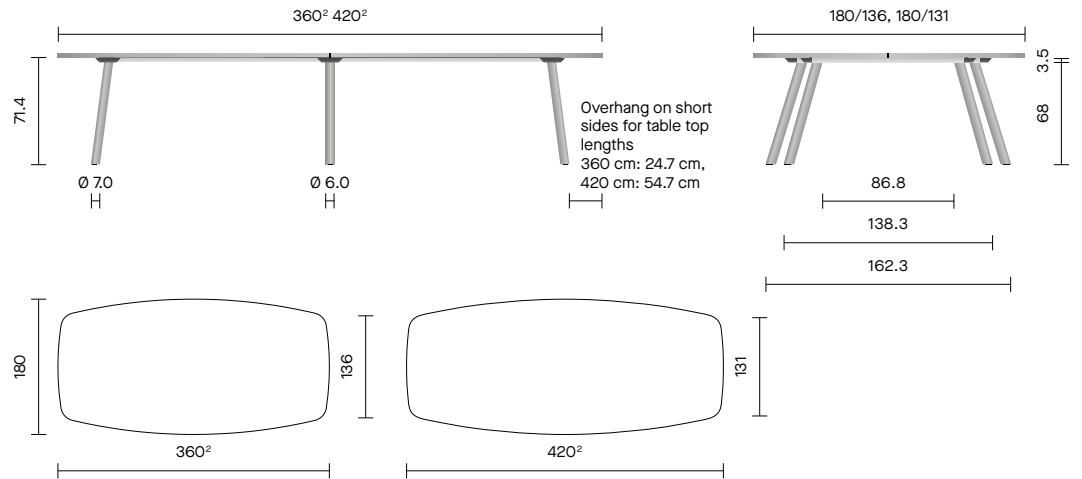

**CREVA MEETING TABLE H RC**

Rectangular bar table,  
without top joint

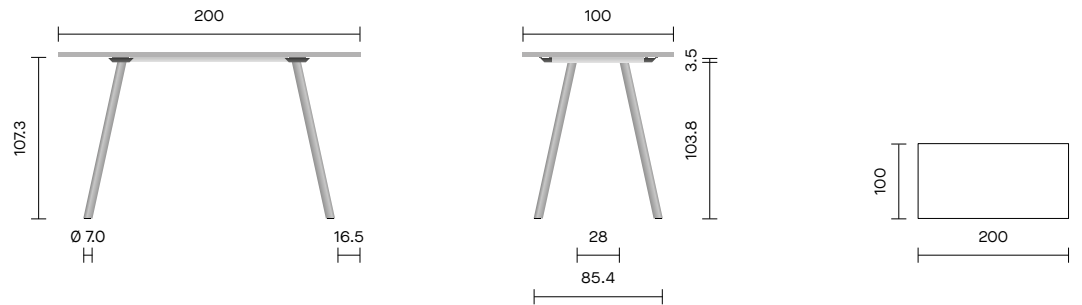

# Product data

## Creva table, without top joint

### CREVA MEETING TABLE H RCR

Curved rectangle bar table,  
without top joint

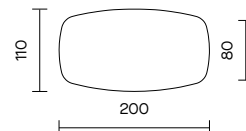
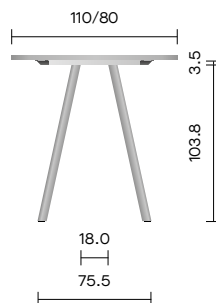
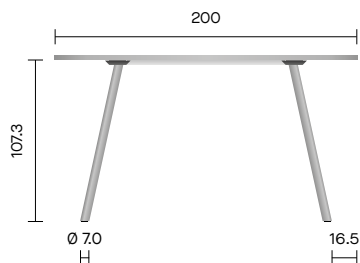

### Accessories

- Plastic glides
- Plastic glides with felt
- Power and data modules (media ports)
- Cable duct, anthracite felt
- 1 leg for power and data with power cable
- 4 legs (tables CREVA MEETING TABLE RC, CREVA MEETING TABLE RCR up to table length 300 cm)
- 6 legs (tables CREVA MEETING TABLE RC, CREVA MEETING TABLE RCR from table length 360 cm)









# Product data

## Creva table, with top joint

### MEETING TABLE RCG

Rectangular table,  
with top joint

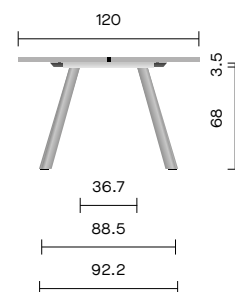
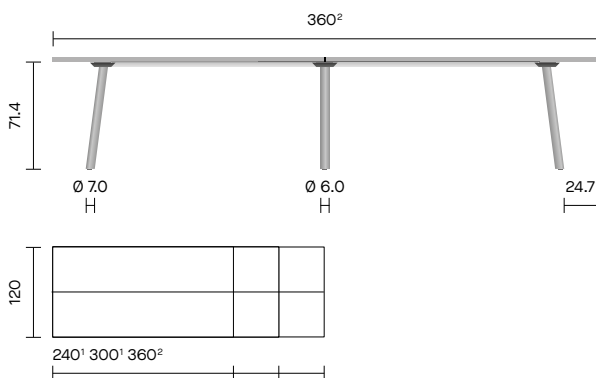
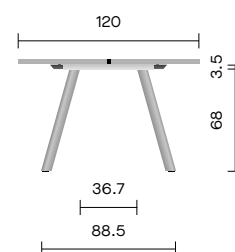
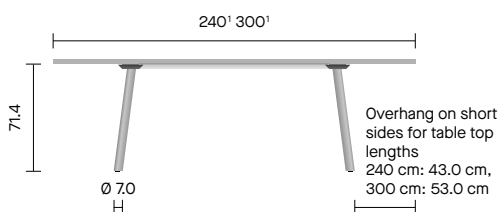
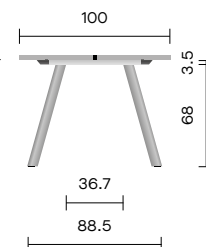
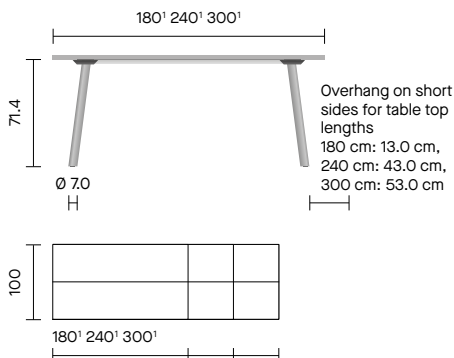

<sup>1</sup> Top in two parts

<sup>2</sup> Top in four parts

Dimensions in cm



# Creva table, with top joint

## MEETING TABLE RCG

Rectangular table,  
with top joint

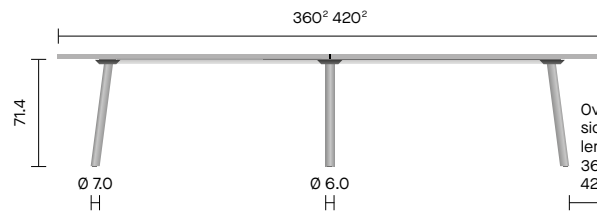
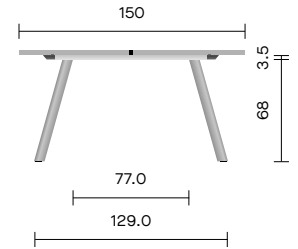
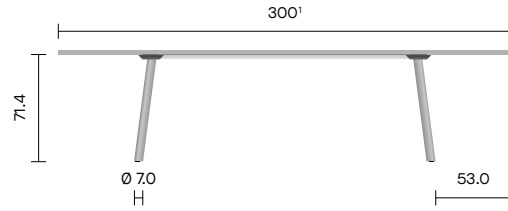

Overhang on short  
sides for table top  
lengths  
360 cm: 24.6 cm,  
420 cm: 54.6 cm

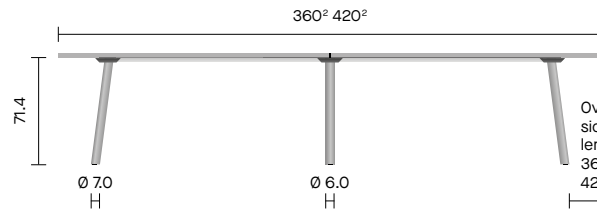
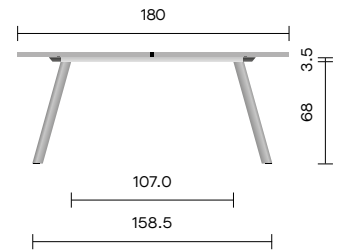
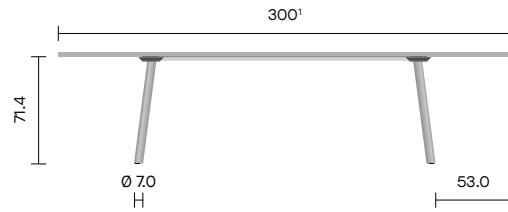
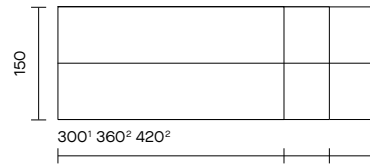
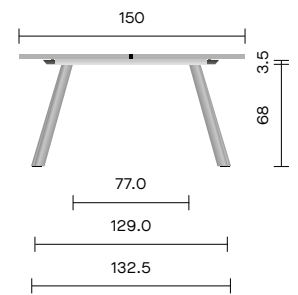

Overhang on short  
sides for table top  
lengths  
360 cm: 24.6 cm,  
420 cm: 54.6 cm

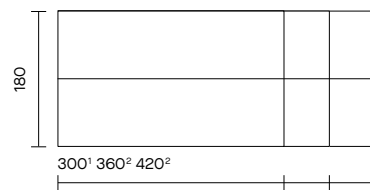
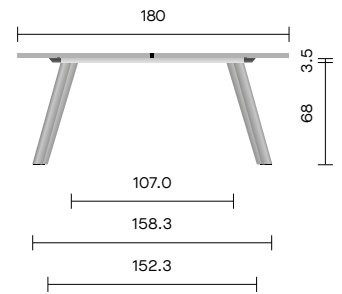

# Product data

## Creva table, with top joint

### MEETING TABLE RCRG

Curved rectangle table, with top joint

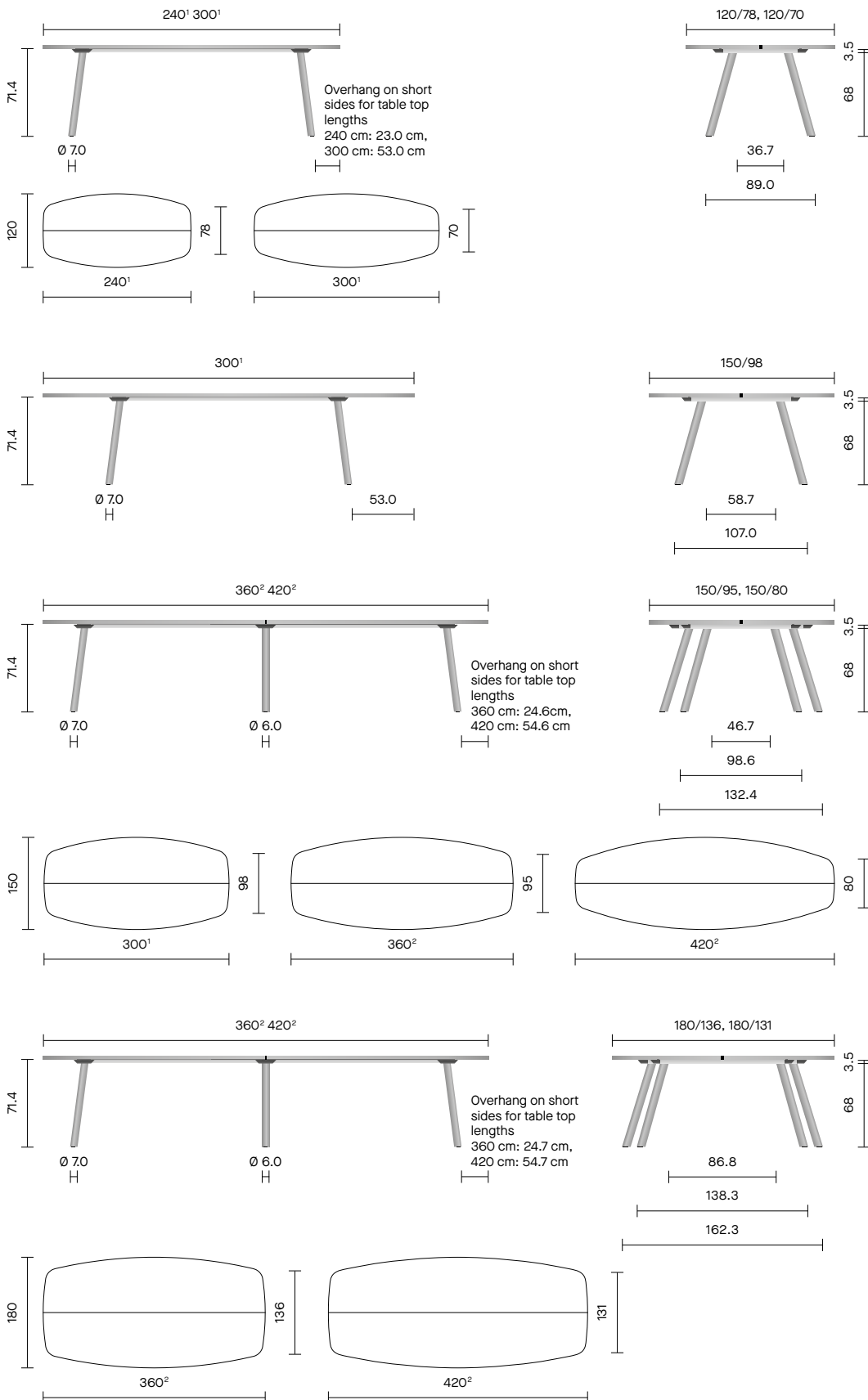

<sup>1</sup> Top in two parts  
<sup>2</sup> Top in four parts

Dimensions in cm

## Creva table, with top joint

### MEETING TABLE H RCG

Rectangular bar table,  
with top joint

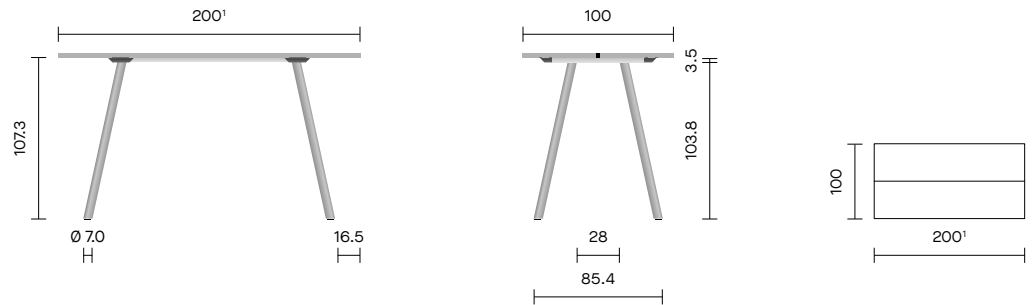

### MEETING TABLE H RCRG

Curved rectangle bar table,  
with top joint

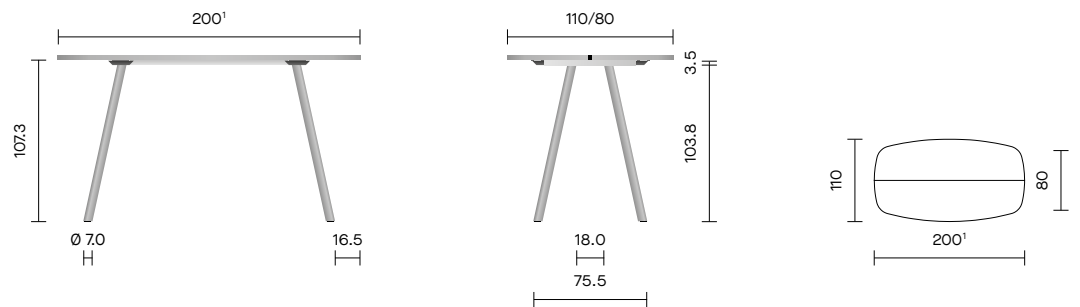

### Accessories

- Plastic glides
- Plastic glides with felt
- View protection panel
- Tray
- Power and data modules (media ports)
- 1 leg for power and data with power cable
- 4 legs (tables MEETING TABLE RCG, MEETING TABLE RCRG up to table length 300 cm)
- 6 legs (tables MEETING TABLE RCG, MEETING TABLE RCRG from table length 360 cm)







shaping the way we sit

# Product data

## Creva table, with top joint

### Power and data (media port)

- Power and data box for 1 insert
  - 1 insert country-specific power socketor
  - 1 insert dual USB charger
- Power and data box for 2 inserts
  - 2 inserts country-specific power socketor
  - 2 inserts dual USB chargeror
  - 1 insert country-specific power socket, 1 insert dual USB charger
- Power and data box for 3 inserts
  - 3 inserts country-specific power socketor
  - 3 inserts dual USB chargeror
  - 2 inserts country-specific power socket, 1 insert dual USB chargeror
  - 1 insert country-specific power socket, 2 inserts dual USB charger
- Cable duct, anthracite felt
- 1 leg for power and data with power cable

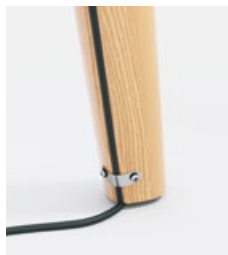

## Creva table

### Curved rectangle tables

In order to measure the widths on the short sides, we measure the table top as if it didn't have rounded edges.

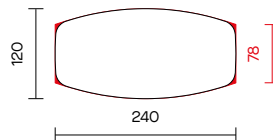

# Materials

---

## Creva table

### Legs, aluminium supporting beams

- Legs natural beech or stained
- Leg mountings RAL 9006 white aluminium powder coated
- Aluminium supporting beams anodised mat silver
- Black plastic closing caps

### Power and data (media port)

- Cable duct, anthracite felt
- Leg for power and data, natural beech or stained
- Power and data box (media port), natural beech or stained in the same stain colour as the legs (for tables with top joint)

### Accessories (for tables with top joint)

- View protection panel, upholstered, fabric according to price list
- Tray, natural beech or stained in the same stain colour as the legs

---

## Type of edge



2 mm  
plastic ABS



2 mm  
natural wood

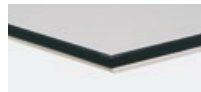

2 mm  
plastic ABS on MDF, 50 mm  
chamfered lipping



1 mm  
plastic PP



1 mm  
plastic PP on MDF, 50 mm  
chamfered lipping



2 mm  
natural wood on MDF,  
50 mm chamfered lipping

# Solutions, quality, sustainability

Excerpt

---

## Fire Prevention

Depending on the environment, contract seating has to be able to fulfil very specific requirements. Interior designers and planners sometimes have to clear difficult hurdles: such as exacting fire prevention regulations. Kusch+Co has worked out individual solutions:

### Wooden parts

As standard, wooden parts as well as high-grade wooden veneer finishes and high-grade wooden veneer edges are protected by a UV curing, environmentally harmless, water-based lacquer meeting all the requirements of "low flammability" acc. to DIN EN 13501 B s2 d0.

### Table tops

Table tops with a 3-layered chipboard core, and featuring either a HPL or real wood veneer surface are project-related also available in a low flammability finish.

Please contact us if you wish to receive the test reports.

Please contact us to receive further information.

---

## Quality

Our environmental and quality management systems are certified acc. to DIN EN ISO 14001:2015 and to DIN EN ISO 9001:2015. External audits as well as our in-house laboratory safeguard our quality level.

The tables of series Creva meet the requirements with regard to stability, static and dynamic load as well as strength and durability in compliance with the current European Directives, standards and regulations.

On top of this, we voluntarily test the strength of our table frames with an additional horizontal load test using higher weights and more test cycles.

To equip our tables, folding tables and table configurations with power and data modules, we use high-quality components made by various manufacturers that have tested their products in accordance with VDE guidelines and the following EU directives:

- Electromagnetic Compatibility Directive 2014/30/EU
- Low Voltage Directive 2014/35/EU
- RoHS3 (Restriction of Hazardous Substances) Directive 2015/863/EU

All of our professionally installed wiring, plugs and netboxes once again undergo electrical testing at our plant and are then labelled and documented as having done so in accordance with DIN EN 50699 VDE 0702: 2016. They are then given a seal of approval and a CE declaration of conformity in accordance with the German Product Safety Act (ProdSG).

---

We are certified in compliance with DIN EN ISO 9001:2015. In our own laboratory, we test our products before their market launch whether they comply with the normative requirements applicable to contract seating, task chairs, and tables, and issue a Declaration of Conformity.

We happily make these Declarations of Conformity as well as our brochure "Mission Statement Quality" providing detailed information on our test procedures available to you – please contact us.



---

## Sustainability

Kusch+Co products stand for long life cycles and optimum recyclability. From the first design drafts of a new product, we take all environmental-relevant components and production processes into consideration, ranging from the materials selection and the design all the way to the manufacturing processes which also contribute towards our sustainable energy balance.









