

comta



KUSCH+CO



The name says it all. Comta stands for Communication Table. These tables go beyond the usual dimensions and are geared towards good communication. All the variations share the same platform – a stable steel frame construction featuring four legs, either made of wood or metal, builds the basis. Dependent on the variation, these tables span large ranges: the tables with standard-issue height carry up to four metre long table tops, the bar table tops can measure up to three metres. The overall overlap provides plenty of legroom and freedom of movement. Trademark feature is the futuristic design language, characterized by slender, tapered legs in an unusual triangular shape. The slender legs give the impression that the table reaches for the sky.



Content

Variations	6
Product data	10
Materials	15
Fire Prevention, quality, sustainability	18
References	19



Design by Kusch+Co Designteam

Under the guidance of Robert de le Roi, the Kusch+Co Designteam creates contract seating series according to the set requirement specifications. These products are characterised by the best possible functionality and a refreshingly new design language. Through the creative input of the entire design team, the outcome is always a joint effort.





Variations

Comta rectangular / stadium-shaped table with wooden legs

These tables are designed for meeting and conference environments. Featuring rectangular or stadium shaped table tops in two different widths and lengths up to 400 cm, depending on the variation. Triangular wooden legs, either made of solid beech or oak.



Comta rectangular / stadium-shaped bar table with wooden legs

Tables designed for modern office environments with a diversity of breakout rooms and meeting points. Also featuring rectangular or stadium shaped table tops in two widths and lengths up to 300 cm. Triangular wooden legs, either made of solid beech or oak.



Comta rectangular / stadium-shaped table with metal legs

Tables where the design language is spiced up with a technical touch. Featuring rectangular or stadium shaped table tops in two different widths and lengths up to 400 cm, depending on the variation. Triangular steel legs, either black or white powder-coated.



Comta rectangular / stadium-shaped bar table with metal legs

Tables designed for use with bar stools. Also featuring rectangular or stadium shaped table tops in two widths and lengths up to 300 cm. Triangular steel legs, either black or white powder-coated.







Product data

Comta rectangular / stadium-shaped table with wooden legs

COMTA MEETING TABLE LGW RC

Rectangular table

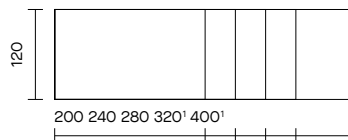
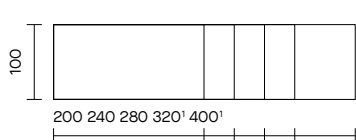
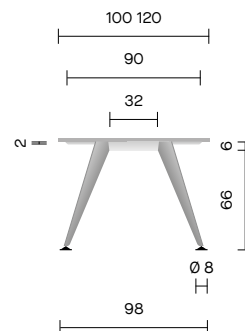
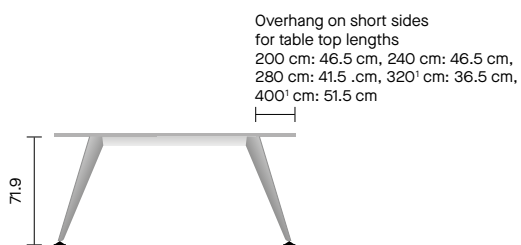

COMTA MEETING TABLE LGW STS

Stadium shaped table

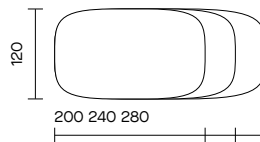
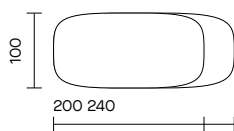
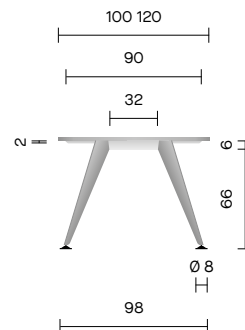
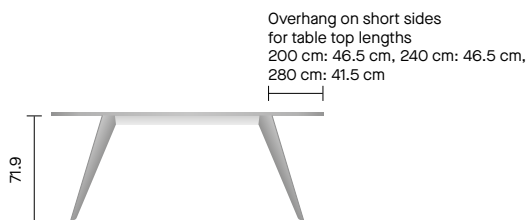

Accessories

- Plastic glides black, nonskid
- Centrally positioned power and data modules (media ports)

¹ Top in two parts

Dimensions in cm

Comta rectangular / stadium-shaped bar table with wooden legs

COMTA MEETING TABLE H LGW RC

Rectangular bar table

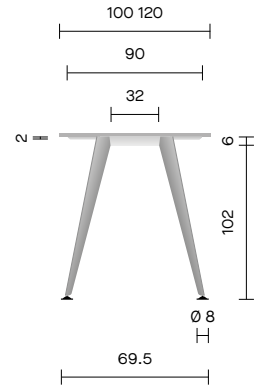
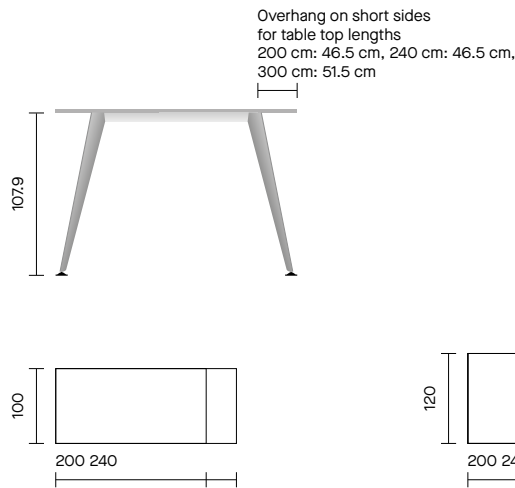

COMTA MEETING TABLE H LGW STS

Stadium shaped bar table

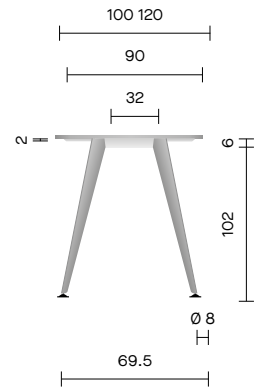
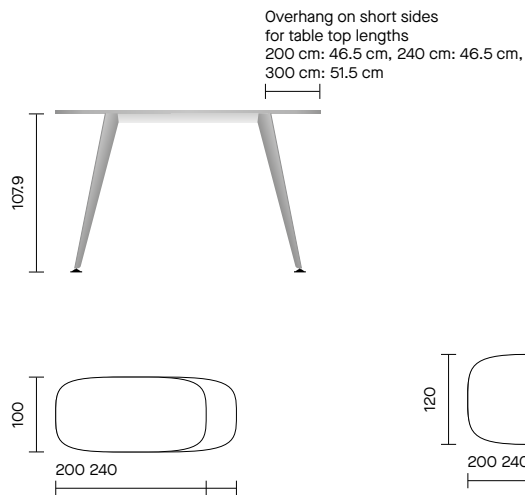

Accessories

- Plastic glides black, nonskid
- Centrally positioned power and data modules (media ports)

Product data

9500 Table, with metal legs

COMTA MEETING TABLE LGM RC

Rectangular table

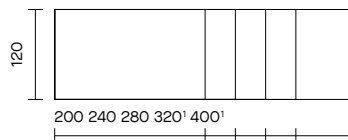
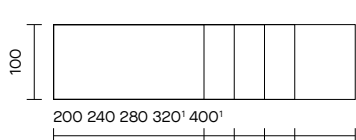
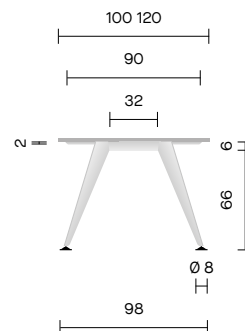
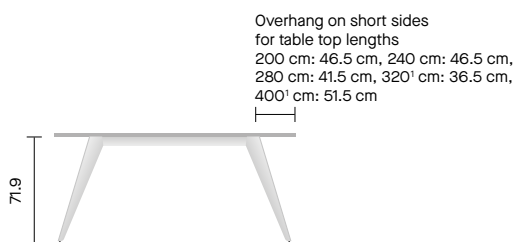

COMTA MEETING TABLE LGM STS

Stadium shaped table

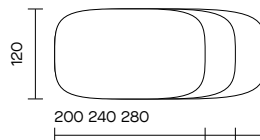
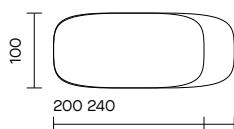
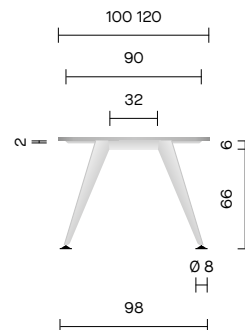
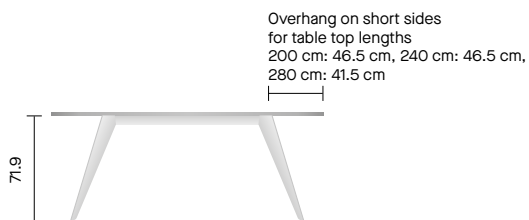

Accessories

- Plastic glides black, nonskid
- Centrally positioned power and data modules (media ports)
- Vertical cable duct in one leg



¹ Top in two parts

Dimensions in cm

Comta rectangular / stadium-shaped bar table with metal legs

COMTA MEETING TABLE H LGM RC

Rectangular bar table

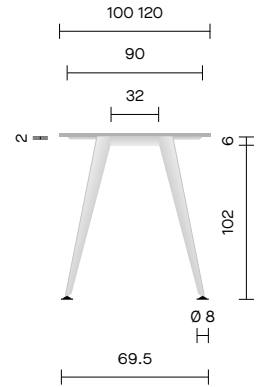
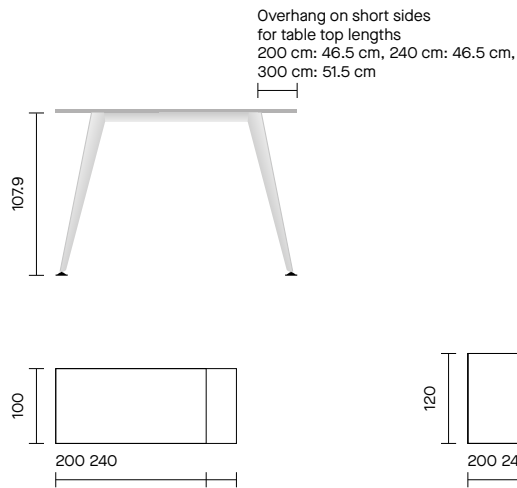

COMTA MEETING TABLE H LGM RC

Stadium shaped bar table

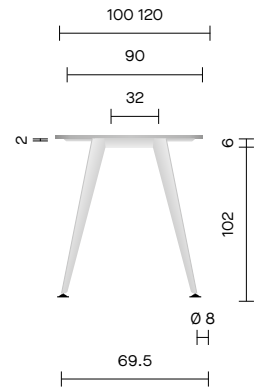
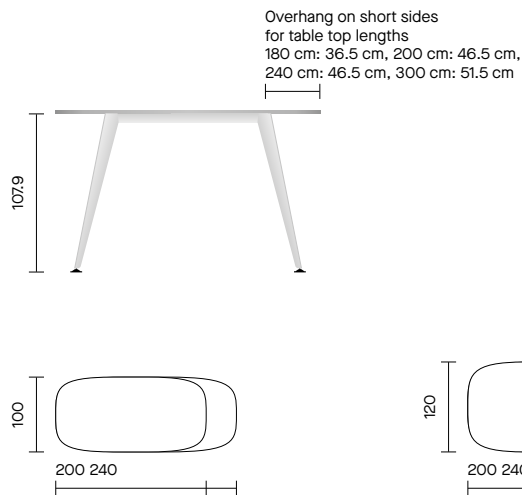

Accessories

- Plastic glides black, nonskid
- Centrally positioned power and data modules (media ports)
- Vertical cable duct in one leg





Materials

Comta

Wooden legs

- Natural beech or stained
- Optional natural oak

Framework

- White or black powder coated steel

Metal legs

- White or black powder coated steel

Type of edge



2 mm
plastic ABS



2 mm
natural wood



1 mm
plastic PP





Location: WK TP, Gießen



Fire Prevention, quality, sustainability

Excerpt

Fire Prevention

Depending on the environment, contract seating has to be able to fulfil very specific requirements. Interior designers and planners sometimes have to clear difficult hurdles: such as exacting fire prevention regulations. Kusch+Co has worked out individual solutions:

Wooden parts

As standard, wooden parts as well as high-grade wooden veneer finishes and high-grade wooden veneer edges are protected by a UV curing, environmentally harmless, water-based lacquer meeting all the requirements of "low flammability" acc. to DIN EN 13501 B s2 d0.

Table tops

Table tops with a 3-layered chipboard core, and featuring either a HPL or real wood veneer surface are project-related also available in a low flammability finish.

Please contact us if you wish to receive the test reports.

Please contact us to receive further information.

Quality

Our environmental and quality management systems are certified acc. to DIN EN ISO 14001:2015 and to DIN EN ISO 9001:2015. External audits as well as our in-house laboratory safeguard our quality level.

The tables of series Comta meet the requirements with regard to stability, static and dynamic load as well as strength and durability in compliance with the current European Directives, standards and regulations.

On top of this, we voluntarily test the strength of our table frames with an additional horizontal load test using higher weights and more test cycles.

To equip our tables, folding tables and table configurations with power and data modules, we use high-quality components made by various manufacturers that have tested their products in accordance with VDE guidelines and the following EU directives:

- Electromagnetic Compatibility Directive 2014/30/EU
- Low Voltage Directive 2014/35/EU
- RoHS3 (Restriction of Hazardous Substances) Directive 2015/863/EU

All of our professionally installed wiring, plugs and netboxes once again undergo electrical testing at our plant and are then labelled and documented as having done so in accordance with DIN EN 50699 VDE 0702: 2016. They are then given a seal of approval and a CE declaration of conformity in accordance with the German Product Safety Act (ProdSG).

We are certified in compliance with DIN EN ISO 9001:2015. In our own laboratory, we test our products before their market launch whether they comply with the normative requirements applicable to contract seating, task chairs, and tables, and issue a Declaration of Conformity.

We happily make these Declarations of Conformity as well as our brochure "Mission Statement Quality" providing detailed information on our test procedures available to you – please contact us.



Sustainability

Kusch+Co products stand for long life cycles and optimum recyclability. From the first design drafts of a new product, we take all environmental-relevant components and production processes into consideration, ranging from the materials selection and the design all the way to the manufacturing processes which also contribute towards our sustainable energy balance.

References

Excerpt



W. & L. Jordan GmbH, Kassel



→ Bodenleuchte
→ Wandleuchte







Aramark GmbH Refreshment Services, Gerlingen

